

PARÇA KODU PART CODE	PARÇA ADI PART NAME	ERKEK TERMİNAL MALE TERMINAL	a ÖLÇÜSÜ (AYAR) a MEASURE (SET)	s ÖLÇÜSÜ (KALINLIK) s MEASURE (THICKNESS)	Malzeme Material	Kaplama / Coating		
						SN	AG	Nİ
TD 2151.50 DP1	MİKRO DİŞİ FİŞ TIR.2.8 B.A.(ESKİ TİP) (0.50) =DP1=	0.50	0.40±0.05	-----	(CuZn30) Pirinç / Brass	-	-	-
TD 2151.50 RP1	MİKRO DİŞİ FİŞ TIR.2.8 B.A.(ESKİ TİP) (0.50) =RP1=	0.50	0.40±0.05	-----	(CuZn30) Pirinç / Brass	-	-	-
TD 2151.50 RPK1	MİKRO DİŞİ FİŞ TIR.2.8 B.A.(ESKİ TİP) (0.50) =RPK1=	0.50	0.40±0.05	-----	(CuZn30) Pirinç / Brass	+	-	-
TD 2151.80 RP1	MİKRO DİŞİ FİŞ TIR.2.8 B.A.(ESKİ TİP) (0.80) =RP1=	0.80	0.70±0.05	-----	(CuZn30) Pirinç / Brass	-	-	-
TD 2151.80 RPK1	MİKRO DİŞİ FİŞ TIR.2.8 B.A.(ESKİ TİP) (0.80) =RPK1=	0.80	0.70±0.05	-----	(CuZn30) Pirinç / Brass	+	-	-

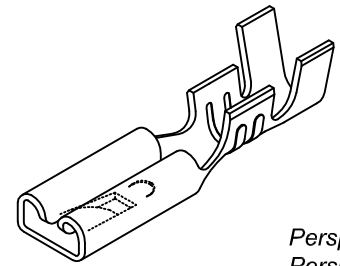
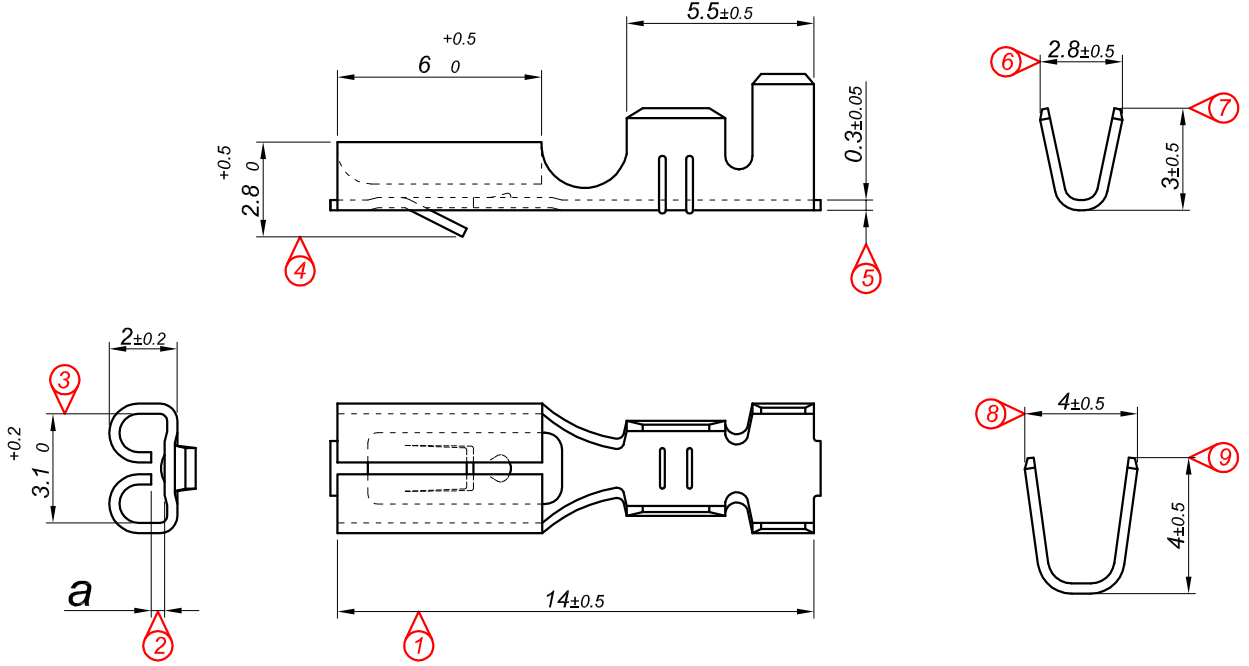

Perspektif
Perspective

Kalıp çıkış yönü
Mold output direction

Makara açılım yönü
Reel opening direction

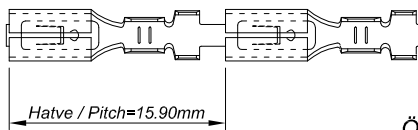

Hatve / Pitch=15.90mm

Ölçek
Scale : 2 / 1

Kablo Kesiti
Wire Section : 0.5 - 1.50 mm²

Resim üzerinden ölçü almayınız
do not measure on drawing

Tarih / Date	15.01.2013	İmza /Signature	Ölçek /Scale			
Çizen / Desing	M.Yağcı		5 / 1			
Onay / Approval	S.Gölcük		No		Değişiklik / Revision	Tarih/Date
	Parça Adı: Part Name	MİKRO DİŞİ FİŞ TIRNAKLI 2.8 BÜYÜK AYAK (ESKİ TİP)			Parça Kodu: Part Code	TD 2151.1